



Moving Forward

BATTERY TECHNICAL DATASHEET

E650L

PRODUCT SPECIFICATIONS

Design Code: 5452332

Approval Date: 12.08.2016

TECHNICAL DRAWING OF E650L

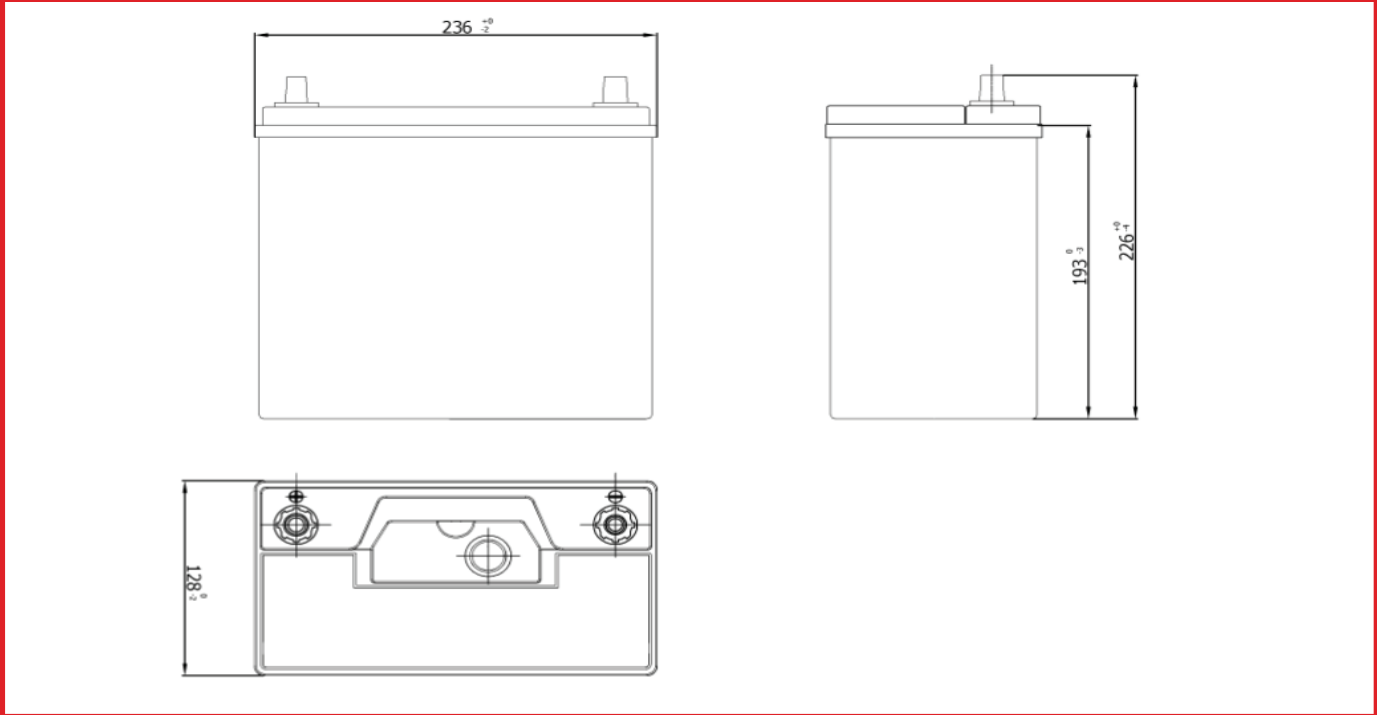

PRODUCT AND PHYSICAL SPECIFICATIONS

BCI GROUP CODE	MODEL NO.	VOLTAGE	CELLS	TERMINAL TYPE	DIMENSIONS			WEIGHT
					L	W	H	
51	E650L	12	6	3	236	128	226	10.92kg ± 3%

ELECTRICAL SPECIFICATIONS

CRANKING PERFORMANCE			RESERVE CAPACITY (Minutes)	CAPACITY AMP HOURS(Ah)
CA @ 0°C	CCA @ 0°F	HCA @ 30°C	@ 25 AMPS	20-Hr
390	360	430	60	45

PRODUCT AND PHYSICAL SPECIFICATIONS

BOX TYPE	BOX COLOUR	HOLD DOWN TYPE	LID TYPE	LID COLOUR	TERMINAL LAYOUT	INDICATOR
NS60	BLACK	-	SMF	BLACK	0	INCLUDED

PHYSICAL BATTERY SPECIFICATIONS DIAGRAMS

HOLD DOWN TYPE	TERMINAL LAYOUT	TERMINAL TYPE
NO HOLD DOWN		<p>3 SMALL DIAMETER TAPERED TERMINAL (JIS)</p>